



# PM Tools & Components

Welcome to the Resource cum Technology Hub for Metal & Plastic Needs

**WE LOVE & LIVE WITH IT**

## Associated Companies

- ✓ Southern Metal Cork Industries (Spring)
- ✓ Surya CNC (Tool room)
- ✓ Neel Coaters



ALWAYS **YES** TO THE CUSTOMER & **FIRST** TO THE CUSTOMER



# PROFILE

A professionally managed and an innovative organisation promoted by a group of technocrats, who have put up decades of services in the manufacturing industry with suitable engineering backgrounds, hands on working knowledge with exposure to international standards and Quality requirements and particularly very Passionate in Manufacturing.

## Mission Statement

Create Wealth, Resources and Talents and Bring Brand Image to Magnetise Customers and Stake Holders.

## Vision Statement

To make P M Tools a World Class Organisation by Increasing its Values in all its Dimensions

## Values

- Be Innovative in every Approaches
- Diversify to the related and far related sectors.
- Be Customer Centric
- Respect Time, make it as Culture
- Be Adoptive
- Be a Magnet





# OUR TEAM

## With Over 100 Years Cumulative Experience

- ✓ Sheet metal expertise of 25 years
- ✓ Plastics expertise 27 years
- ✓ Program management expertise 17 years
- ✓ Surface treatment expertise 12 years

LEADERSHIP TEAM



Papanna Reddy K  
G Chairman



Manju G R  
Managing Director



Balavelayutham G  
CEO

OPERATIONAL TEAM

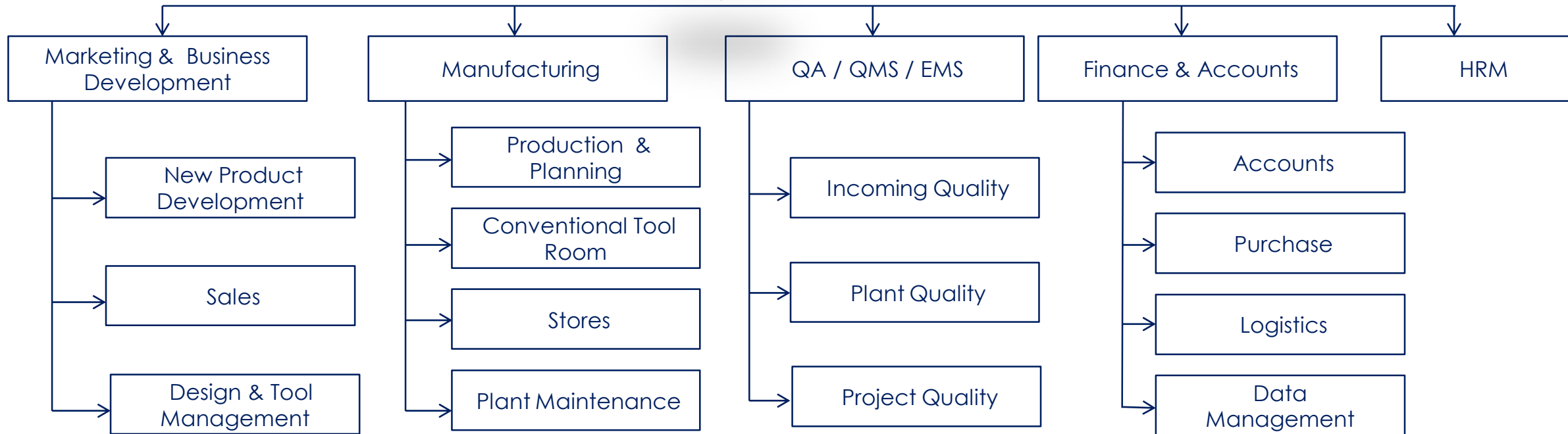

ALWAYS **YES** TO THE CUSTOMER & **FIRST** TO THE CUSTOMER



# Our Journey

2010

The Company Blossomed in a rental area of 5000 sq. ft. with 5 employees.

2014

Increased the Power press machines capacity with additions of 30T & 75T Machines.

2011

Facility Accredited with ISO 9001:2008 Certification Entered in to Automotive Segment and become supplier for M/s Sogefi ( As Tier-1)

2015

Further Equipped the facility with 50T Multi slide forming machine . Upgraded the Quality Systems with ISO 9001:2015 certification. Added further with Wire bending Machines (CNC)

2012

1<sup>st</sup> Expansion taken-up. Added Power Press Machines from o10T to 50T range. Also have become Vendor Partner for M/s. JBM Ogihara Automotive Industries

2016

Become Proud Vendor Partner for M/s. VARROC GROUP (TCPL)

2013

Added the Facility with Multislide Forming Machines. (25T)

2017

Constructed Own Plant with 22,000 sq. ft. area Facility at Harohalli Industrial area. Another Feather in to the Cap, become Vendor Partner for M/s Parker Hannifin as Tier-1 Supplier.





# Our Journey

2018

Added our facility with EDM Wire cutting and Super drill machines.  
Accredited with IATF 16949 : 2016 certification

2022

Entry to OEM's TVS, JBM & TTID. EV battery box projects, Pulley project for textile industries etc

2019

Added with further SEW Series press machines with a tonnage of 63T, 110T, 160T.  
Become suppliers for M/s/ AEON Tele Electronics Pvt. Ltd. Premier Plasmatic & VR Engineering.

2023

Target to entry AL, export, spring unit., Rapid proto type

2020

Started entering in to many OEM as Tire 1 Supplier and included advanced

2021

Started the Construction of two facilities. One for Plating and another for Plastic Injection Moulding in PM Tools own premises and the facilities are expected to be operational by Mid of Year 2022.



ALWAYS **YES** TO THE CUSTOMER & **FIRST** TO THE CUSTOMER



# Key Highlights

Competent project management teams

Fast Proto delivery with tool room facilities, Outsource depends less

Assemble line for special process and machine concept development



Design facility for Product, Press tool and Injection tool  
By using advance Design software like VISI,

Delivery 100% committed

Production Facilities Press, forming, bending, laser cutting machines etc



ALWAYS **YES** TO THE CUSTOMER & **FIRST** TO THE CUSTOMER



# We Do

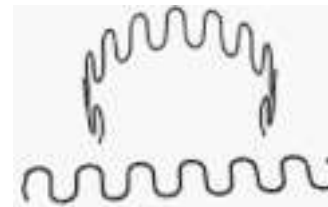
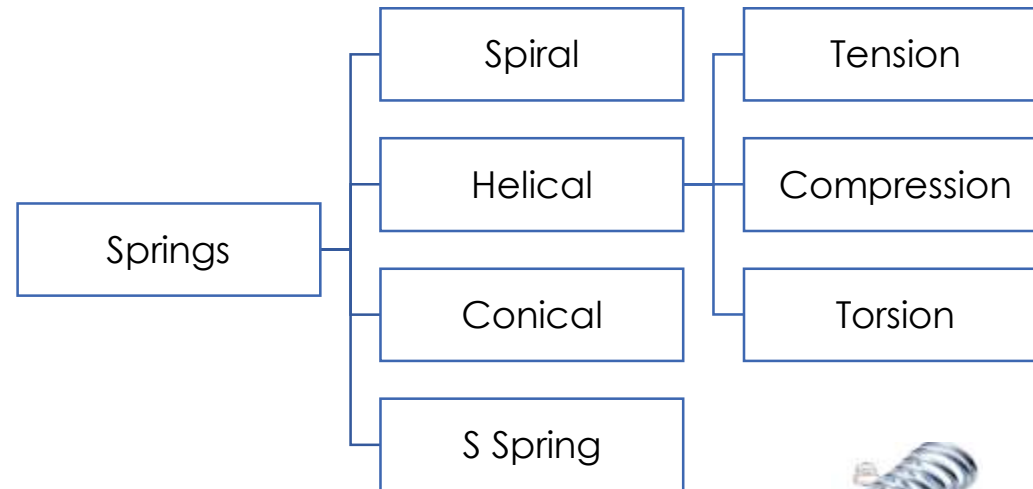
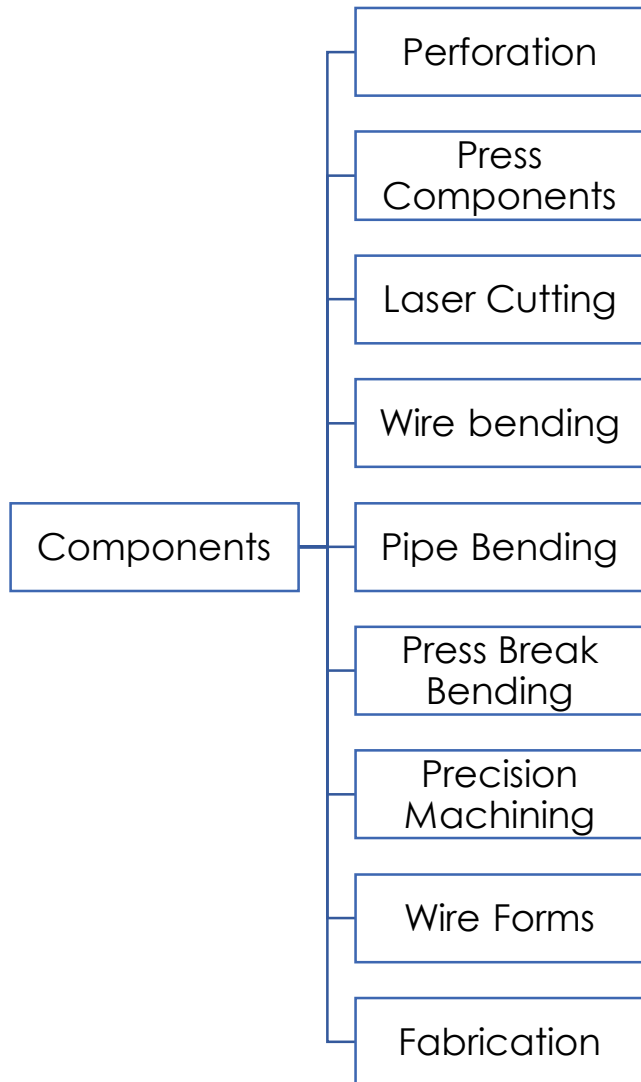



# Manufacturing Facilities

## 5 Axis CNC Pipe Bending



## CNC Laser Cutting



## CNC Sheet Bending (150T)



## CNC Wire Bending 3mm - 11mm



ALWAYS **YES** TO THE CUSTOMER & **FIRST** TO THE CUSTOMER





# Manufacturing Facilities

## Multi Forming Machine

No. of Machines: 5



## Wire former Machine

No. of Machines: 2



## Rolling machine (Upto 60 Dia)



## Tube & Rod head forming Machines



ALWAYS **YES** TO THE CUSTOMER & **FIRST** TO THE CUSTOMER



# Manufacturing Facilities

## Press Machines

Tonnage	200 T	160 T	110 T	80 T	63 T	45/50T	35 T	20 T	10 T
No. Of M/c (Press)	3	3	2	3	3	6	3	5	6



**High Speed Press**  
No. of Machines: 3 (25T)



## Tool Room Facilities

### CNC 3-Axis VMC



### Wire Cut EDM



### CNC Turning Center



### S-Spring machine



### Auto Surface Grinding



Lathe Machine



Milling Machine



ALWAYS **YES** TO THE CUSTOMER & **FIRST** TO THE CUSTOMER



# Manufacturing Facilities

## Spot Welding

No. of Machines: 9



## Projection Welding

No. of Machines: 4



## Seam Welding

No. of Machines: 1



ALWAYS **YES** TO THE CUSTOMER & **FIRST** TO THE CUSTOMER



# Manufacturing Facilities

SL No.	List of Machines	Qty
1	POWER PRESS 150T	1
2	"SEW" POWER PRESS	20(+9)
3	MULTISLIDE FORMING	4
4	WIRE BENDING (CNC)	2
5	WIRE FORMER MACHINE (CNC)	2
6	MECHANICAL PRESS	13
7	PROJECTION WELD	4
8	SEAM WELDING (SPM)	1
9	SPOT WELD	9
10	TAPPING	4
11	PERFORATION	4



ALWAYS **YES** TO THE CUSTOMER & **FIRST** TO THE CUSTOMER



# Tool Room Facilities

SL No	Description	Range
1	EDM Wire cut machine	320 X 220 X 200 mm
2	Super Drill	400 X 300 X 300 mm
3	Surface grinding -2	300 X 600 + 1200 x 600
4	Lathe	6 FEET
5	DRO Milling machine	565 X 305
6	Drilling Machine	25 mm
7	HMT Milling Machine	800 X 400 mm





Coating thickness gauge



Vernier Caliper

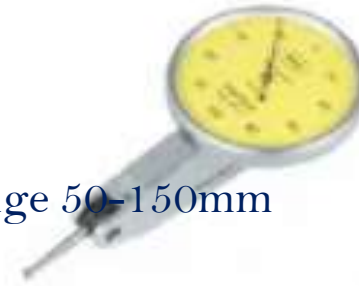

Bore Gauge 50-150mm



Height Master



Lux Meter



Micro Meter 0-25mm

Vickers Hardness Tester



Profile Projector

Hardness Tester



Height Gauge 0-300mm

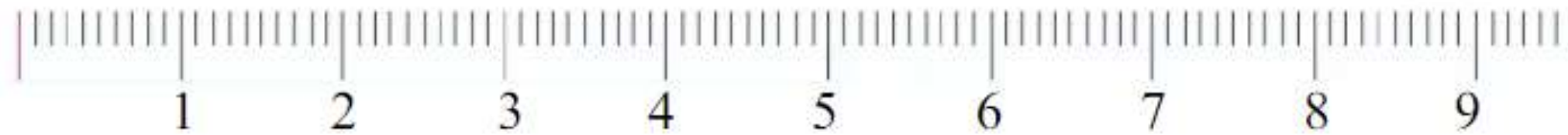

QUALITY CONTROL

# Metrology & Inspection

Verification of manufactured parts to ensure all the required specifications are in conformance with the customer requirement.



ALWAYS **YES** TO THE CUSTOMER & **FIRST** TO THE CUSTOMER



# Product Applications



Automobile Parts



Mechanical Assemblies



Photocopiers



Washing Machines



Seat Assemblies



Electrical Appliances



Electrical Apparatus



Relays, Circuit-Breakers, Switches



Computer Keyboards, Monitors



Toys & Locks



Communication Equipments



Cassette Recorders, Cameras, Watches &



ALWAYS **YES** TO THE CUSTOMER & **FIRST** TO THE CUSTOMER



# Product Gallery

Hose clamps, nut clips



Housing clamps



Hose clips



All type of spring



Mesh, filter parts



Pipe forming parts



Wire forming parts



ICC cricket helmet gird



ALWAYS **YES** TO THE CUSTOMER & **FIRST** TO THE CUSTOMER





# Product Gallery

End caps & filter parts



Press parts



Pulley



Battery charger box

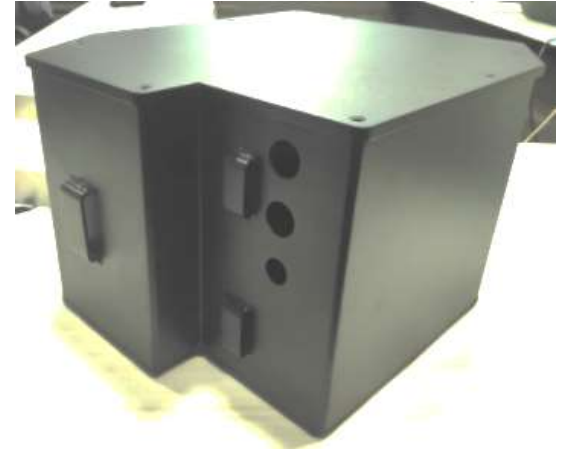

Electrical & Electronics parts



Worm clamp



Hose clamp



Head form parts



Molded parts

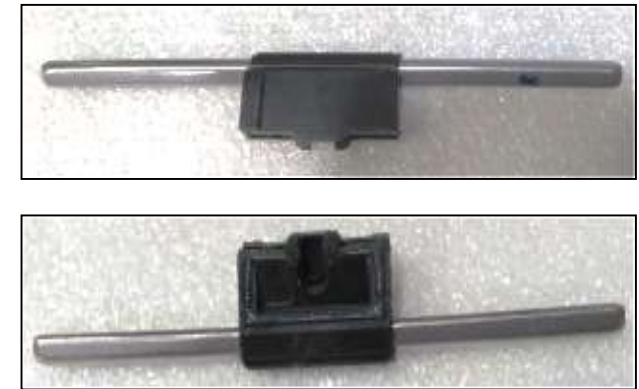

ALWAYS **YES** TO THE CUSTOMER & **FIRST** TO THE CUSTOMER



# Product Gallery

## Fabrication parts

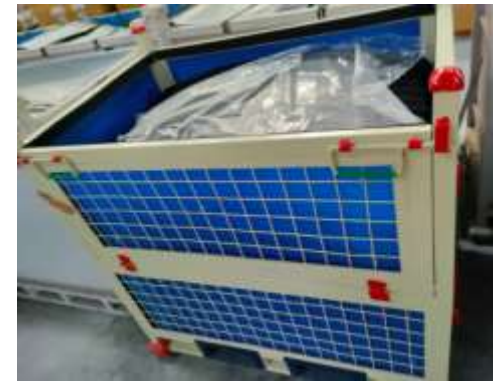

ALWAYS **YES** TO THE CUSTOMER & **FIRST** TO THE CUSTOMER



# Clients



WIREFORM COMPONENTS  
INDIA Pvt. Ltd.



ALWAYS **YES** TO THE CUSTOMER & **FIRST** TO THE CUSTOMER



# End Clients



ALWAYS **YES** TO THE CUSTOMER & **FIRST** TO THE CUSTOMER

# Accreditations

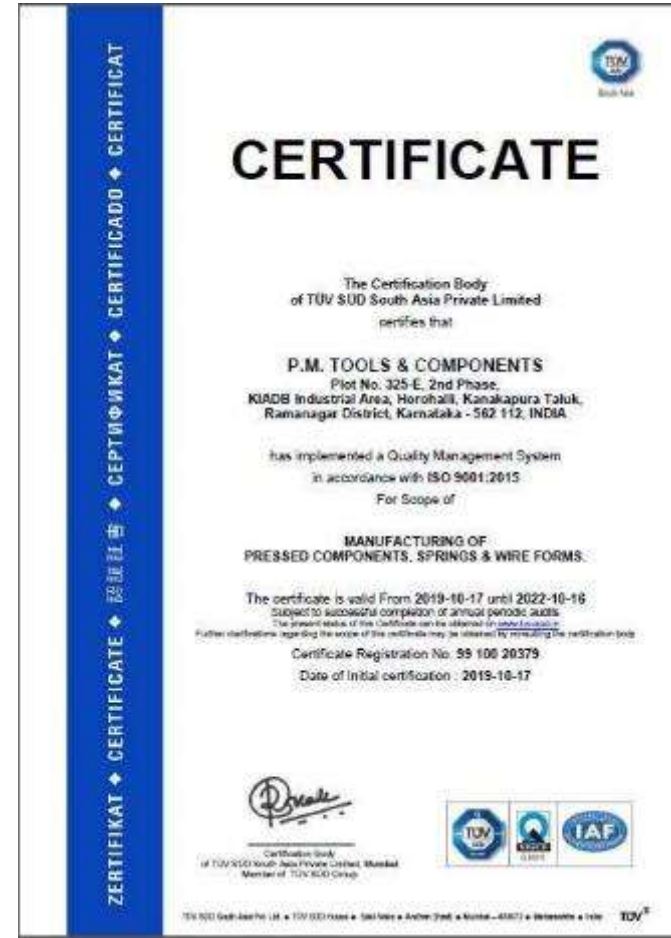
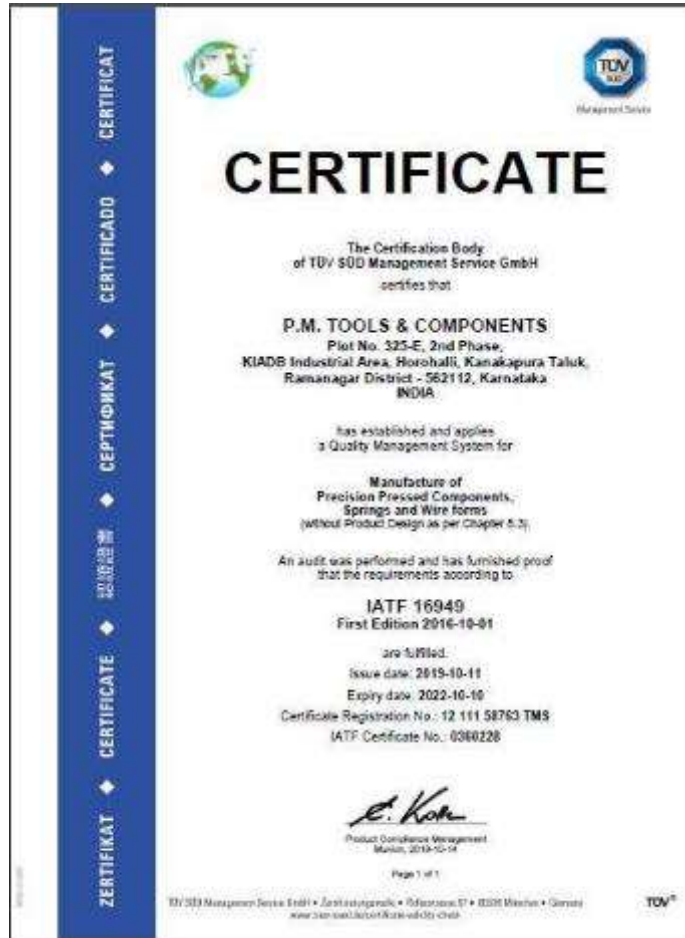

ALWAYS **YES** TO THE CUSTOMER & **FIRST** TO THE CUSTOMER

# Blessings



ALWAYS **YES** TO THE CUSTOMER & **FIRST** TO THE CUSTOMER



# Contacts

Mr. PAPANNA REDDY K G  
**CHAIRMAN**

+91- 98452 33061

[pappanna@pmtools.co.in](mailto:pappanna@pmtools.co.in)

Mr. BALAVELAYUTHAM G  
**CEO**

+91-9894770959

+91-9632455133

[balavelayutham.g@pmtools.co.in](mailto:balavelayutham.g@pmtools.co.in)

Mr. Mahendran P  
**NPD Project Head**

+91-9886014965

+91-9751591801

[mahendran@pmtools.co.in](mailto:mahendran@pmtools.co.in)

Mr. MANJU G R  
**Managing Director**

+91- 98804 54838

[manju.gr@pmtools.co.in](mailto:manju.gr@pmtools.co.in)  
[pmtoolings@gmail.com](mailto:pmtoolings@gmail.com)

Mr. SAYOOJ CR  
**Quality**

+91- 99026 12288

[sayooj.cr@pmtools.co.in](mailto:sayooj.cr@pmtools.co.in)  
[quality@pmtools.co.in](mailto:quality@pmtools.co.in)

Mr. Akshay Kumar Naik  
**Sales and Business Development**

+91-99024 62288

[akshaykumar.naik@pmtools.co.in](mailto:akshaykumar.naik@pmtools.co.in)



P. M. Tools & Components

#325-E, 2nd Phase, KIADB Industrial Area, Hulisid...

<http://www.pmtools.co.in/>

<https://goo.gl/maps/4VWoWeeXuLhwGe667>



ALWAYS **YES** TO THE CUSTOMER & **FIRST** TO THE CUSTOMER



# PM Tools & Components

*ALWAYS AT  
YOUR BEST  
SERVICES!..*

**Thank You!**

